

siegling transilon

conveyor and processing belts

RECOMMENDATIONS FOR MACHINE DESIGN

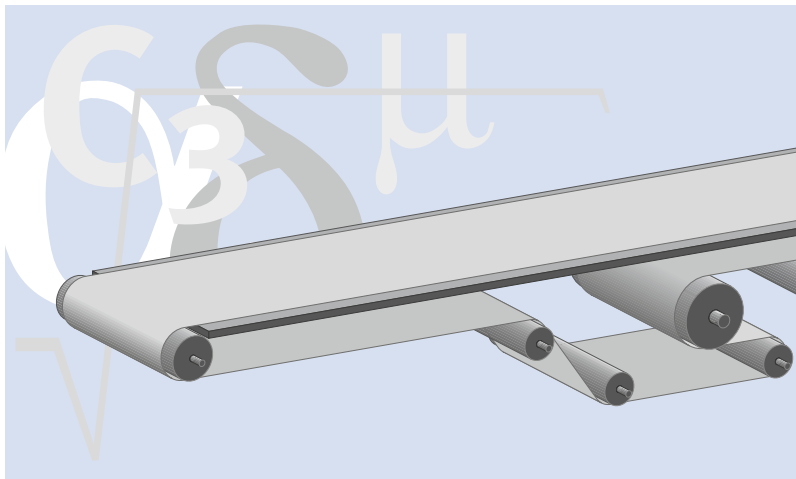

For further information, see our brochure
no. 304 Calculation methods – conveyor belts.

Contents

- 2 Definitions and description
- 3 Drums
- 5 Take-up systems
- 6 Belt support
- 9 Knife edges
- 10 Belt tracking
- 19 Cleaning devices

DEFINITIONS AND DESCRIPTION

In standard conveyors for light materials handling, the conveyor belt runs over two end drums (in this case end and drive drums).

The best configuration, called a head drive, is where the drive drum is at the end of the conveyor where the products are discharged. In this case, the forces operating are being applied more efficiently than they would be with a tail drive (see calculations).

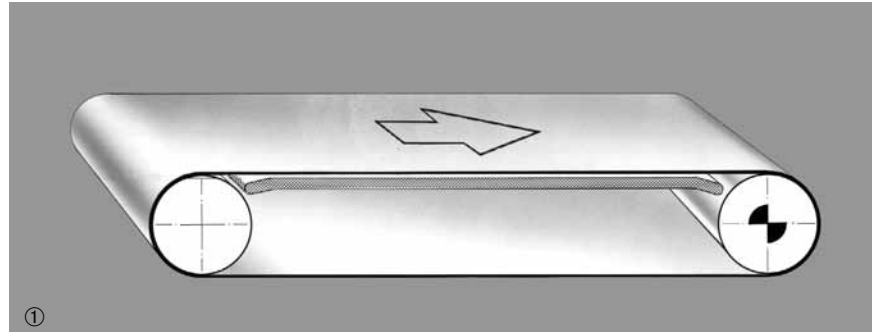

In long conveyors and with heavy loads, support rollers are often used instead of slider beds to reduce the effective pull. The end drum should be fitted so that its position is adjustable, so it can function as a tension drum. With centre distances greater than 2000 mm, support rollers should also be installed on the return side. This prevents excessive belt sag from the belt's own weight. ②

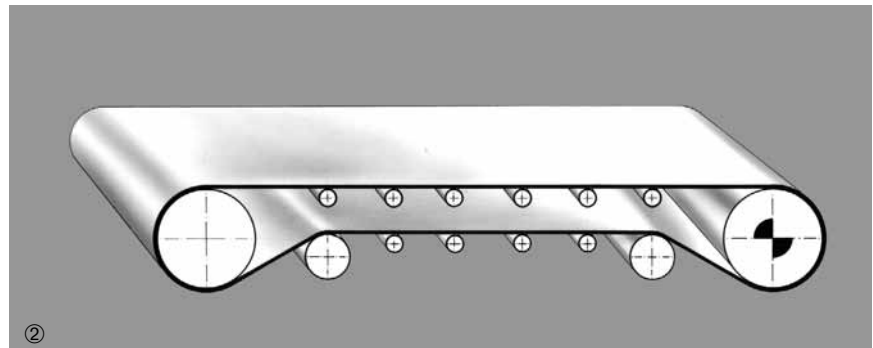

If the centre distance cannot or only slightly be adjusted, e.g. because conveyors are positioned directly after one another, take-up systems are put on the return side. ③

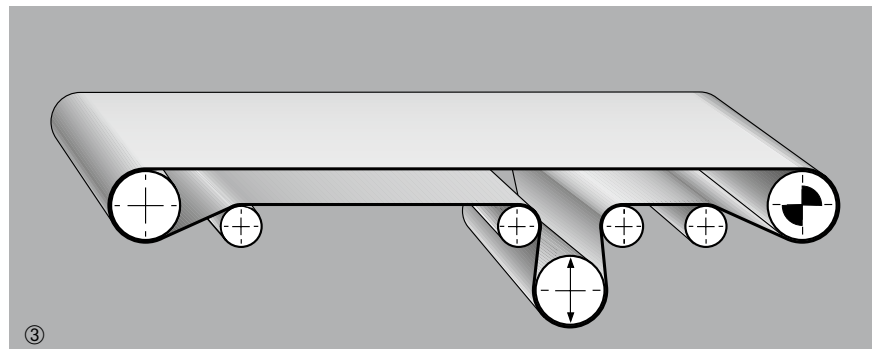

In light materials handling, conveyors with troughed belts are used for conveying bulk goods. In this case, two or three-section sets of support rollers are fitted to the upper side. Alternatively the belt support can be troughed.

Please see page 8 for more information on the transition area between the drum and trough.

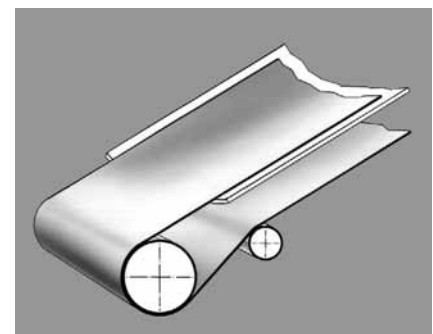
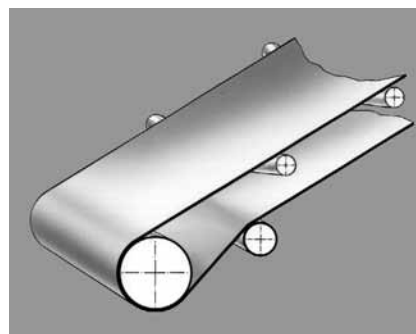

DRUMS

Drum diameter

Particularly in wide conveyors, drums with diameters that are too small are subject to inadmissibly significant deflection, resulting in unwanted belt creasing and mistracking.

Make a counter-check (see page 17).

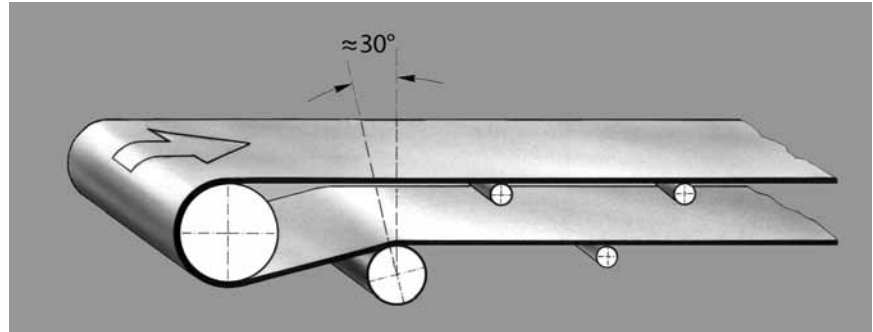

Drum diameters should always be as large as possible. The minimum diameter permitted is determined by:

- The effective pull to be transmitted (see method for calculating the drive drum diameter).
- The flexural properties of the belt used (see d_{min} in the product range).
- The flexural properties of the lateral and longitudinal profiles welded on (Technical Information 2, ref. no. 318).

Drive drum

The crown height values, stated in the table below under lines II and III, are maximum values and should in certain exceptional cases be reduced to match those in line I. In particular if lateral forces cause the belt to crease otherwise.

This also applies to centre drives, or wide belts where the distances between the end and drive drum are too small to compensate for the tension in the belt.

The drive drum can be cylindrical, if tracking devices are used.

We recommend the drive has a cylindrical centre section with tapered edges. The length of the cylindrical section of the drum should be $b/2$.

For further information, please see page 11.

If the belt width is considerably less than the drum length, the belt width determines the proportions of the drive drum.

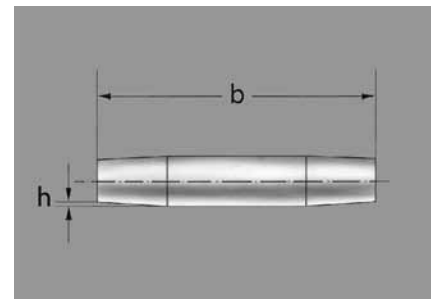

Guidelines for conicity h [mm]		Drum diameter [mm]		
		to 200	> 200 to 500	> 500
I	Single-ply belts	0.5	0.8	1.0
II	Double-ply belts NOVO, E10/M, E15/M, E20/M	0.7	1.3	1.5
III	3-ply belts	1.0	1.6	2.0

DRUMS

Lagged surface

As regards O, U0, A0, E0, V1, U1, UH coatings, drum lagging is often applied to improve friction on the drive drum. The lagging should be made of an abrasion-resistant material, like polyurethane or rubber.

Plastic laggings should have a hardness of at least 85 Shore A at 20°C in order to avoid too much wear and tear. Rubber laggings should have a hardness of more than 65 Shore A and be made of an abrasion-resistant rubber.

Another method that customers can apply themselves is to wind friction lagging, e.g. Siegling Transilon with U2 coating, in a spiral form around the drum.

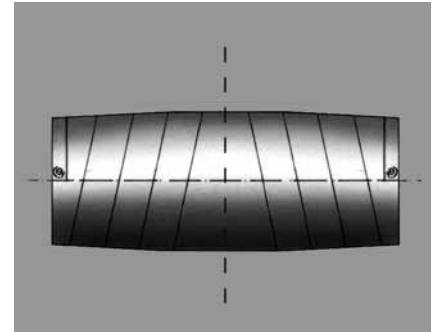

To avoid any guidance problems, we recommend, particularly where broad drums are concerned, winding the friction lagging symmetrically for both sides towards the centre of the drum. Any existing patterns or profiled drum laggings (e.g. with rhomboid patterns) must also be symmetrical to the centre of the drum.

Bare surface

The faces of all drums should be smooth. Any pronounced grooves caused by rotation of the drum will have a detrimental effect on tracking. Roughness $R_z \leq 25$ (DIN EN ISO 4287) (Peak to valley height $\leq 25 \mu\text{m}$)

Similarly to the wound drum lagging method, we recommend that wide drums with a bare surface should also be lathed asymmetrically from either side to the centre.

Any rotational grooves left on the drum will be symmetrical and therefore neutral in terms of tracking.

TAKE-UP SYSTEMS

Screw-operated take-up system

The contact pressure of the belt on the drive drum, required to transmit the effective pull, is produced by elongating the belt using a tensioning device.

The end drum can serve as a tensioning drum, if its position can be adjusted by screws (remaining parallel to the drive drum).

Conveyors are often configured like this when Siegling Transilon is used, because Siegling Transilon hardly stretches at all (meaning a short take-up) and is virtually dimensionally stable (requiring no re-tensioning).

An inflexible tensioning device would however not permit any compensation for belts lengthening if they stretch when the conveyor starts up, or due to unequal loads, or the impact of temperature.

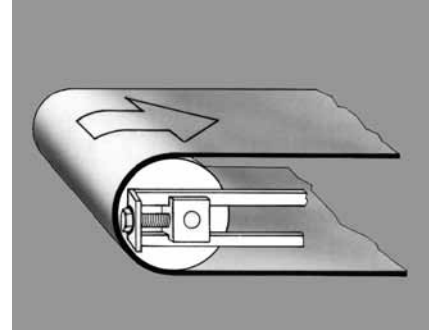

Force-dependent take-up systems

On very long, heavily-loaded conveyors, this take-up system should be located directly after the drive drum to compensate immediately for elongations on the top face when the conveyor starts up.

Force-dependent tensioning can for example be achieved with a weight suspended from a rope or cord. Alternatively, pneumatic, hydraulic or spring-loaded take-up systems can be used.

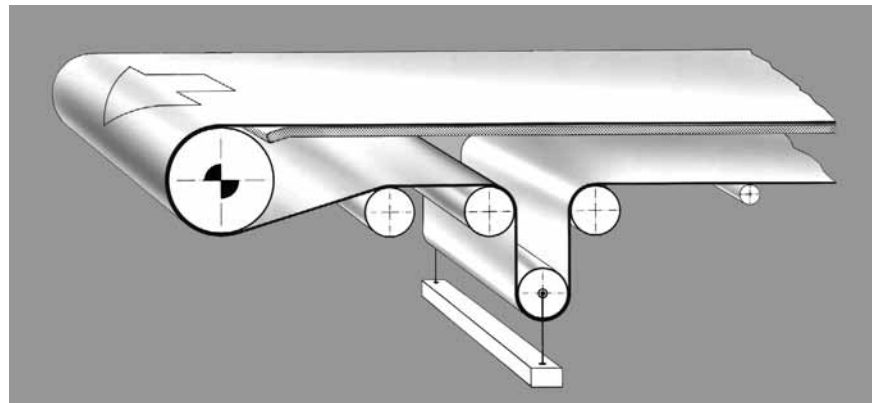

Force-dependent take-up systems are recommended in high and fluctuating temperatures.

A force-dependent take-up system is not suitable for reversible drives.

BELT SUPPORT

Slider bed

Slider beds have to be adjusted exactly, because due to sliding friction they have a strong impact on the belt. Their edges must be chamfered off. Place support areas about 2 to 3 mm lower than the belt.

Generally sheet metal, hard plastics (Resopal, Duropal or similar) and bonded plywood are used as support material. Together with the smooth undersides of Siegling Transilon belts, these materials have excellent friction behaviour. Depending on the surface properties and conditions the belts are operated in, it may be necessary to make alterations.

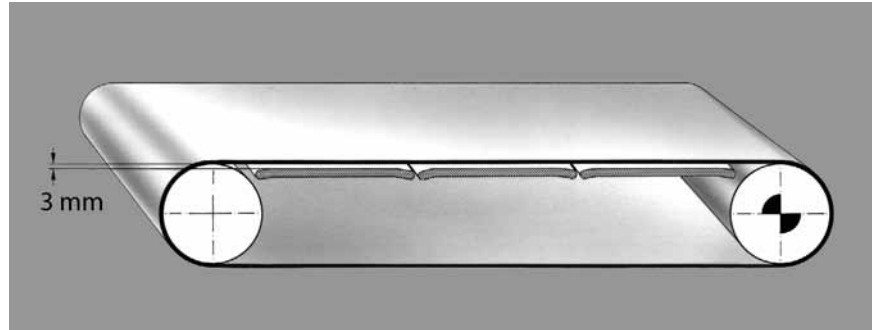

Avoid slatted frames as supports if possible, as they often increase the wear and tear on the belt and noise when the belt is running.

It is important to clean the sliding supports before switching on the conveyor, as residues from protective paints or varnishes, or other dirt can cause significant disturbances (e.g. tracking problems, damage to the belt and increased friction).

Support rollers

Support rollers are commonly associated with low levels of drag and smooth tracking behaviour. For this reason they are almost exclusively equipped with roller bearings and low friction sealing. To keep their moment of inertia as low as possible, the roller tube is usually made of precision steel tubes or small flue tubes (see DIN EN 10220).

Plastic support rollers are also used (the advantage: they are corrosion resistant and very dirt resistant. Please note: electrostatic build-up is possible).

The support roller pitch is determined according to the length of the edge of the unit good you want to convey. If the support roller pitch is $\leq \frac{1}{2}$ edge length, the weight of the goods will always be borne by two rollers.

Support roller layout

Layouts and dimensions of support rollers are laid down in DIN 22107/ ISO 1537. The purpose of the M form (DIN term) is to support the belt when driven in a flat state on the top and return side and the troughed belt on the return side. On the top face, troughed belts are always supported by support rollers in an N or P shape.

Two-piece sets of support rollers should have a staggered layout and overlap by approx. 10 mm.

In the case of a two-piece support roller layout where there is no overlap, the gap between the support rollers must be kept as small as possible to avoid creases.

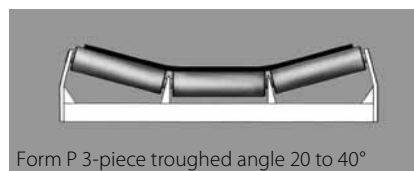
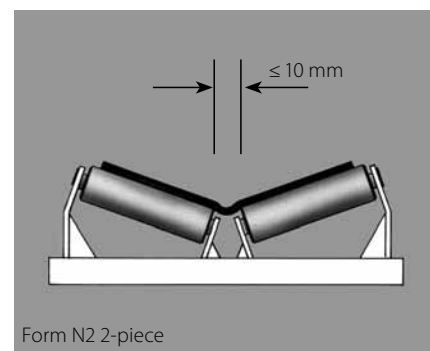
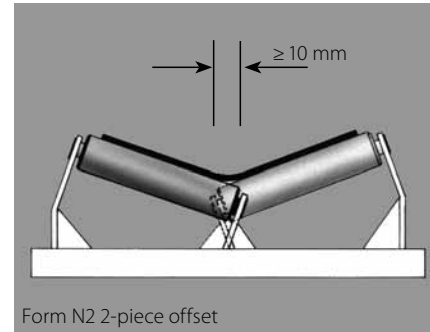
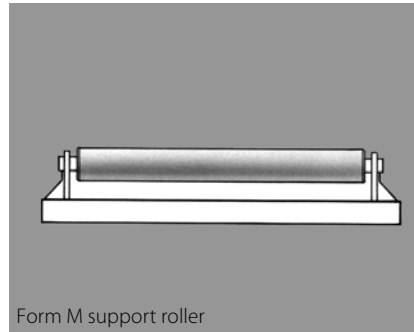

Support roller pitch for unit goods

The distances between the support rollers are determined according to the length of the edge of the unit goods you want to convey. If the support roller distance is $\leq \frac{1}{2}$ edge length, the goods are always supported by two rollers.

The support roller pitch depends on the belt pull and the masses. The following formula is used to calculate it:

$$l_0 = \sqrt{\frac{y_B \cdot 800 \cdot F}{m'_0 + m'_B}} \quad [\text{mm}]$$

$$F = \varepsilon\% \cdot k_{1\%} \cdot b_0 \quad [\text{N}]$$

If maximum sag of 1% is permitted, in other words if $y_B = 0.01 l_0$ is used, then

$$l_0 = \frac{8 \cdot F}{m'_0 + m'_B} \quad [\text{mm}]$$

Recommendation: $l_0 \text{ max} \leq 2 b_0$
 $l_u \approx 2 - 3 l_0 \text{ max}$

- l_0 = Support roller pitch on upper side [mm]
- l_u = Support roller pitch on the return side [mm]
- y_B = Maximum conveyor belt sag [mm]
- F = Belt pull in the place concerned in N
- $m'_0 + m'_B$ = Weight of goods conveyed and belt in kg/m
- $k_{1\%}$ = Relaxed tension/elongation value in accordance with ISO 21181 in N/mm width
- b_0 = Belt width in mm
- $\varepsilon\%$ = Elongation at fitting

BELT SUPPORT

Snub rollers

Snub rollers are used when:

- The conveyor belts' arc of contact on the drive drums is to be increased;
- The distance between the top and return side must be small for design or construction reasons.

When using belts with a patterned surface, we recommend lagging the drums to reduce noise

Minimum diameters for small arcs of contact

If the arc of contact of snub rollers, support and guide rollers is small, the diameters of these rollers may equal $1/2 d_{min}$, as long as the arc of contact does not exceed 15° (for d_{min} see appropriate data sheets).

Transition lengths

The top edge of the end drum must align with the top edges of the centre troughing rollers.

In the transition area of the troughed belt from the drum to the belt support point (and vice versa) the edges are subjected to increased elongation.

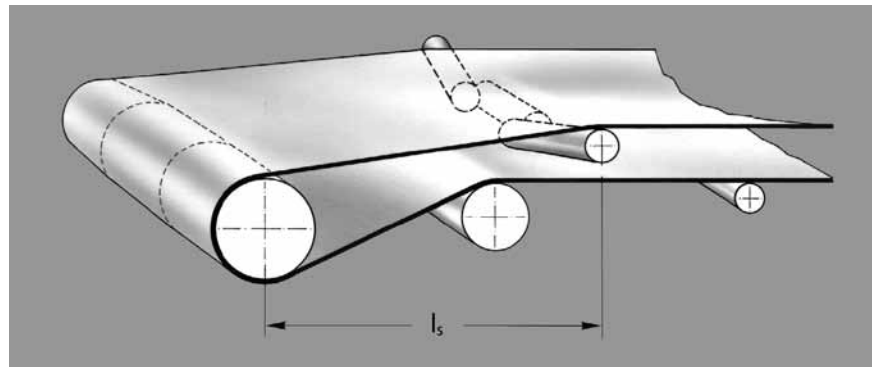

As a result, the following guidelines should be observed for the transition length l_s :

Please note: to ensure proper belt guidance, we recommend the end drum should be a tapered/cylindrical design.

$$l_s = \text{belt width } b_0 \cdot \text{Factor } c_7 \quad [\text{mm}]$$

Troughing angle	15°	20°	30°	40°
c_7	0.7	0.9	1.5	2

If the trough-shaped belt is supported by metal sheets, their edges towards the end rollers have to be well chamfered. In this case, we recommend you contact Forbo Siegling application engineers.

KNIFE EDGES

Fixed knife edges

The belt's energy consumption increases when it rotates round a knife edge. At the same time, because of the friction on the knife edge at high velocities, the belt can heat up significantly.

Where elongation at fitting is low ($< 0.3\%$) this friction can cause the belt to shrink lengthways.

For this reason, the arc of contact should be as small as possible (low power consumption and heat build-up, little pre-tensioning required).

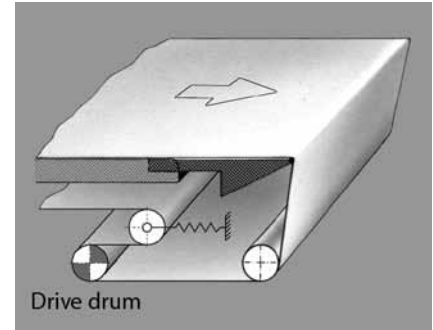
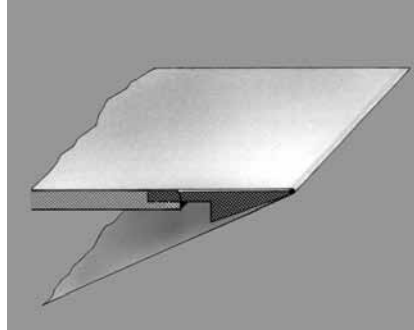

If the knife edge belt only runs in one direction, instead of the usual screw tension take-up, a force-dependent tension roller can be installed after the drive drum to ensure correct elongation in the belt. This moveable tension

roller decreases the belt tension on the knife edge and, in comparison with the fixed screw tension take-up, can reduce the frictional force on the knife edge considerably.

Rolling knife edges

Rolling knife edges are increasingly being used because the friction on the knife edge is reduced significantly. Knife edge radii of 4–10 mm are normally used.

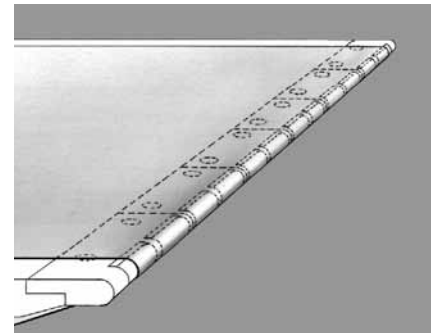

BELT TRACKING

Fundamentals of straight conveyor belt tracking

The conveyor must be as rigid as possible. Its shape must be unaffected by forces exerted by the belt.

All drums on the conveyor, particularly the drive drum, must be clean. Remove rust inhibitor, oil, encrusted dirt from slider beds or supports, drums and rollers. Exchange damaged or heavily-worn parts.

Align knife edges, drive and end drums, as well as support rollers so that they are parallel.

Align the end drums so that they are parallel to each other and at right angles to the conveyor, by adjusting the drums till each centre distance 1 and each diagonal 2 are equal.

Another method is first to align the drive drum so that it is at right angles and then adjust the end drum till the centre distances 1 are equal.

Starting from the end drum, you can then align each support roller or table/slider bed section individually so that the axles are parallel.

Goods should always be loaded onto the centre of the belt and in the direction conveyed. Goods must not be dropped from large heights.

Attention should be paid to the surface quality of the drums.

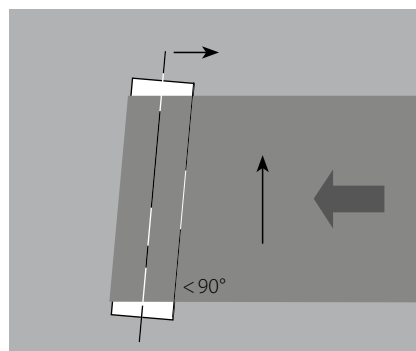
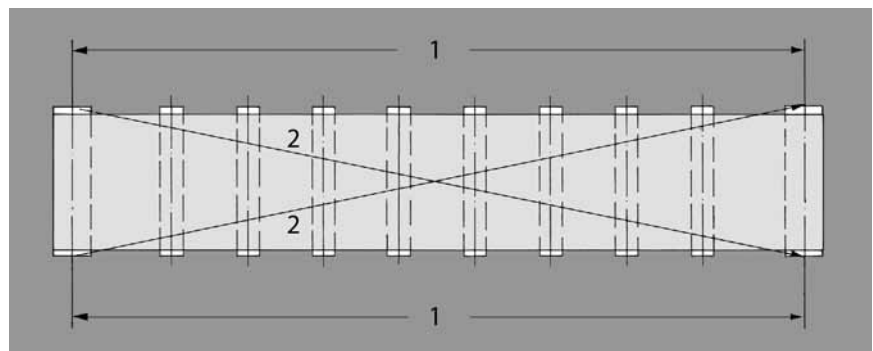

Misaligned drums will cause belt mistracking.

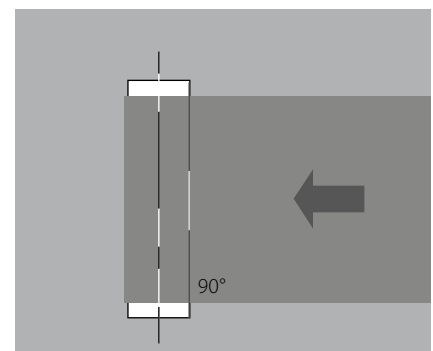

Drums are aligned at right angles: the belt runs straight.

Effect of temperature

An uneven distribution of heat and load on the belt will lead to non-uniform changes in its inner tension state.

This creates control forces that may cause the belt to mistrack. We recommend using an automatic belt tracking device.

Effect of conicity and belt width

A tapered/cylindrical drum centres a conveyor belt.

The higher the belt velocity and drum diameter, the greater the centring effect.

For recommendations on conicity, refer to page 3.

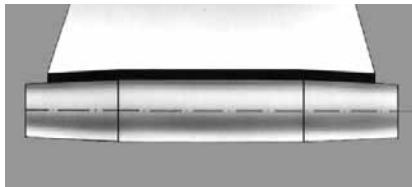

The drum is tapered/cylindrical.

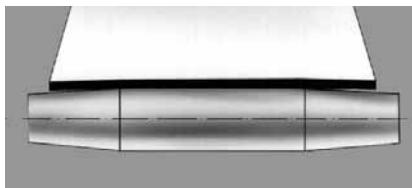

Excessive conicity. The belt does not hug drum and is not guided. If the centre distance is small, select elongation at fitting so that the belt edges always hug the drum.

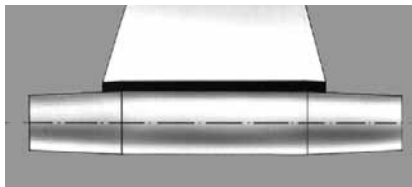

Belt is too narrow. Solution: Match drum proportions to belt width.

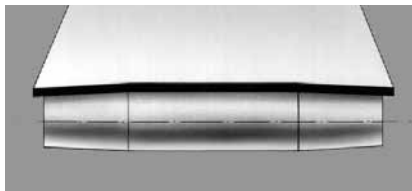

Belt is wider than the drum. Avoid at all costs because of uneven control, above all in laterally flexible belt types.

BELT TRACKING

Effect of support rollers

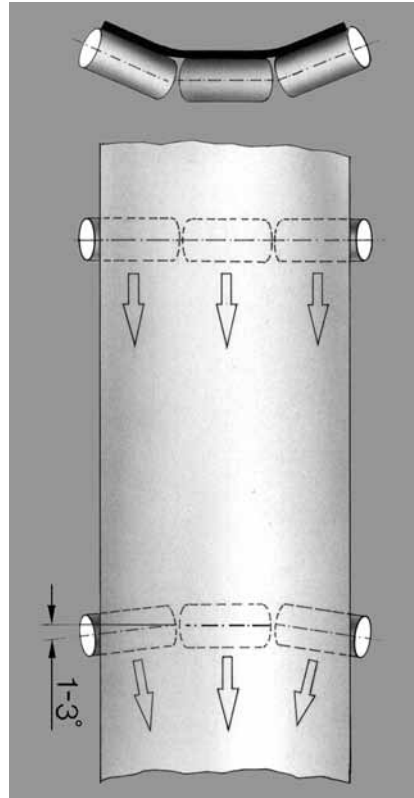

Depending on the belt velocity, troughed belt tracking can be improved by rotating some of the side rollers up to approx. 3° in direction of belt travel.

You can often control non-troughed belts adequately by installing some support rollers, so that their horizontal position can be adjusted. You can then pivot them by about 2–4°. We recommend this method for long belts.

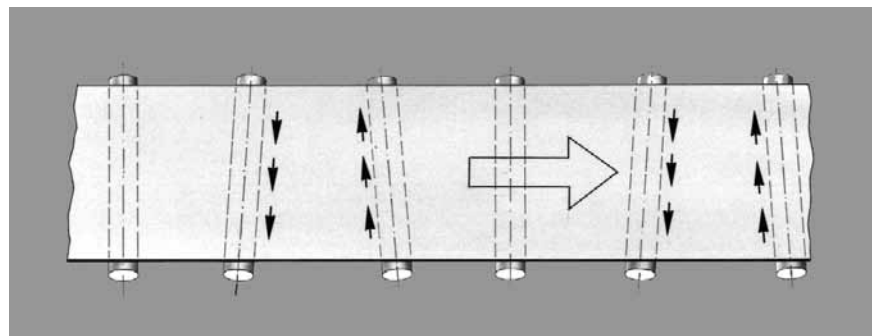

Effect of negatively-troughed rollers

A negatively-troughed set of rollers on the return side centres the belt quite well if placed near the tail drum.

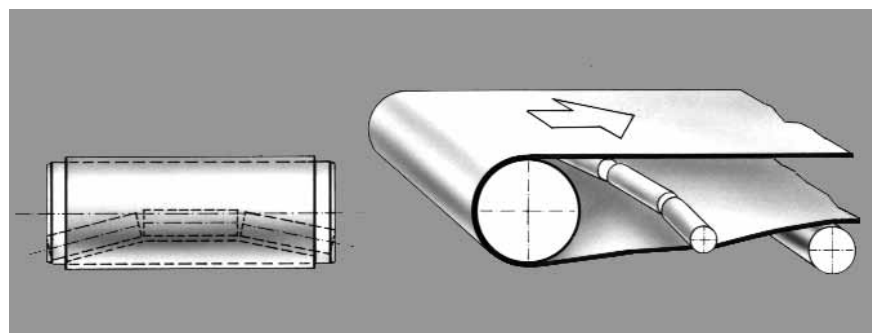

Belt control with tapered/cylindrical drums

Adjustment

- Fit the belt and drums A + B so that their axles are parallel until the elongation at fitting you require is reached.
- You can correct belt tracking by tensioning or slackening one end of the tension drum. The conveyor belt will move towards the slacker belt edge.
- You might need to use a belt guidance system close to the end drum (e.g. with short, wide belts).

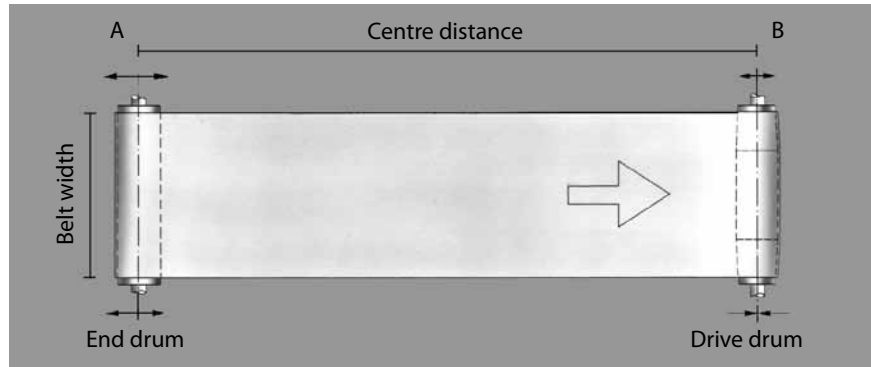

Tapered/cylindrical drums should be adjustable in order to compensate for production tolerances in the conveyor and the belt. If conveyors are ≥ 5 m long, both end drums should be tapered/cylindrical.

If tapered/cylindrical drums do not guide the belt sufficiently, rollers placed at an angle, or automatic belt control devices can be used.

In square conveyors (centre distance \sim belt width) or where even poorer length to width ratios occur, the belt can no longer be adjusted with tapered/cylindrical drums. We recommend using an automatic belt control system (page 15).

Using snub rollers

Adjustment

- All drums must be in their basic setting so that their axles are parallel.
- Fit the belt and adjust tension drum B (keeping the axle parallel to other drums) until the tension required has been achieved.
- Adjust belt tracking with drums C and D. You might have to install a belt tracking system, by using drum C or D as the control drum.

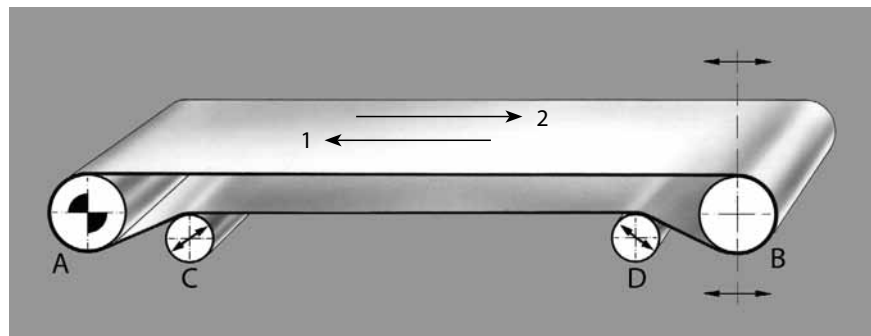

Very efficient tracking is achieved if you use snub rollers C and D, above all when these come into contact with the coated side of the conveyor belt (because of a good friction coefficient).

The most efficient control is always provided by the snub roller at the end drum; by snub roller D running in direction 1 and snub roller C running in direction 2.

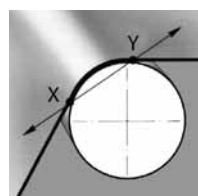

The snub rollers should be adjustable along the XY axis (where the belt tracks upwards and downwards). As a result, the belt edges are hardly affected at all and major distortion of the fabric is prevented. By using snub rollers that can be adjusted by motor, very effective automatic belt control can be achieved (see page 15).

BELT TRACKING

Take-up system on the return side

Adjustment

- All drums must be in their basic setting so that their axles are parallel.
- Fit the belt and adjust tension drum E (keeping its axles parallel with the other drums) until the tension required has been achieved.
- Adjust the belt tracking with snub roller C and if necessary with end drums G and F or plate H. You might need a belt guidance system here.

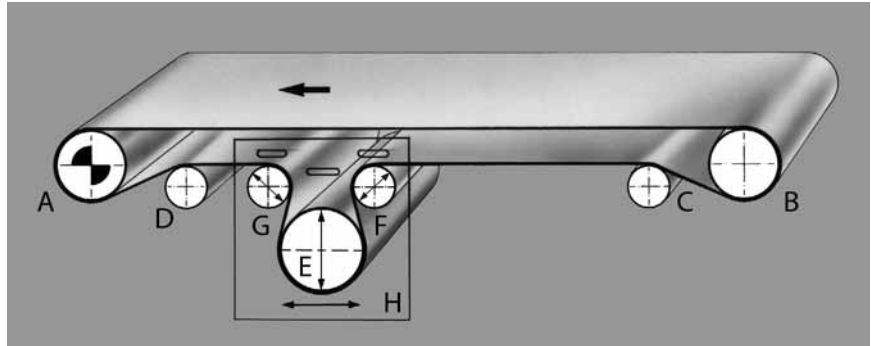

End rollers G and F and tension drum E can be adjusted in the direction the arrow is pointing in, whereby the tension drum E can also be used as a drive.

Please refer to the following and previous pages for more information on the layout, design and control properties of drums A, B, C and D.

One simple solution is to mount drums G, F and E on a plate H as a single unit which is adjustable in the direction the arrow is pointing in.

Reversing conveyors

Adjustment

- All drums must be in their basic setting so that their axles are parallel.
- Fit the belt and adjust tension drum B (keeping its axles parallel with the other drums) until the tension required has been achieved.
- In reversing conveyors, belt tracking should be adjusted on the tapered/cylindrical drums, not the snub rollers.

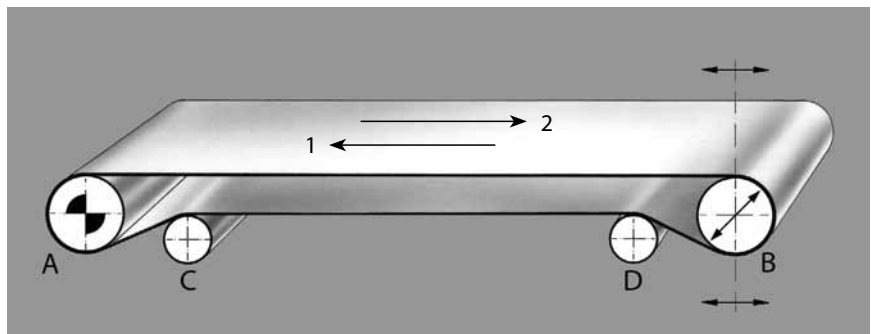

Important for perfect tracking in reverse operation is the precision with which the conveyor and belt have been manufactured.

It takes some time until the drums have been correctly adjusted. We recommend using a belt control system for both directions in very short and wide conveyors.

Adjusting the belts for reverse operation takes some skill. A belt adjusted in one direction, often mistracks in the other direction.

Knife edge conveyors

Adjustment

- Adjust all drums and the knife edge so that axles are parallel.
- Fit the belt and adjust tension drum C till its axles are parallel with the other drums and the tension required has been achieved. Keep the belt tension as low as possible to avoid applying unnecessary stress and the build up of heat (due to friction) on the knife edge.
- Adjust belt tracking with drums B, C, D and E or plate H. A belt guidance system might be advisable.

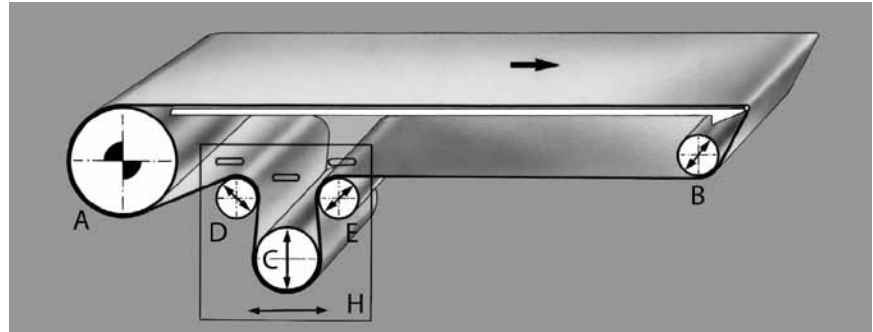

Shorter knife edge belts can be guided, as shown in the figure above. Drive drum A should be tapered/cylindrical, end drums B, D, E and tension drum C cylindrical and adjustable in the direction the arrow is pointing in, so that the belt can be adjusted.

Automatic belt guidance systems are generally used for long knife edge conveyors (e.g. in cooling tunnels). Belt tracking is indicated by belt edge sensors.

As outlined on page 14, drums C, D and E can be mounted onto an adjustable plate H.

Belt edge sensors

There are different kinds of belt edge sensors, e.g. mechanical, hydraulic, electrical, optical and pneumatic. They activate the control system when differences in the position of the belt edge occur.

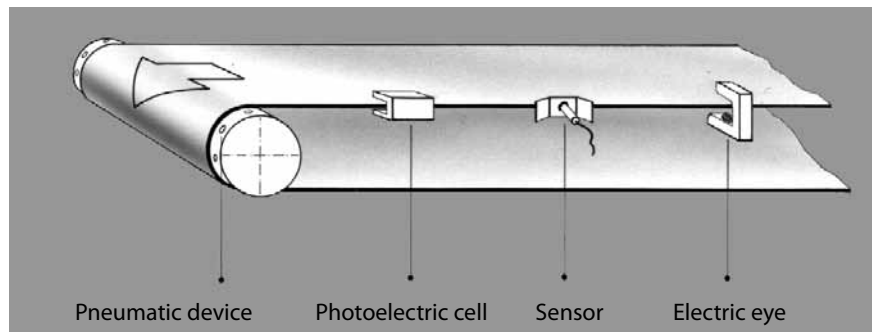

Belts are often controlled automatically by using swivel-mounted snub rollers. They are usually adjusted with the aid of electrically-operated threaded spindles, or pneumatic cylinders after the actual values of the belt edges have been identified by the sensors.

Purely mechanical solutions without auxiliary power are also possible in small conveyors.

Automatic belt control

BELT TRACKING

Using belts with longitudinal profiles

Transversal forces can be absorbed by longitudinal profiles that have been welded on. These profiles should be supported by grooves in the slider bed and not transmit any transversal forces to the end drums. The grooves in the end drums must be at least 8–10 mm wider than the profile.

This rule applies to center distances of >1.5 m. Where center distances are <1.5 m, lateral guidance can also be provided via the grooves in the end drums but, in this case, the slider bed grooves must then be wider. We recommend that you consult Forbo Siegling's application engineers about the design.

Please see Technical Information 2, ref. no. 318 which gives details of minimum belt lengths, profile dimensions, types and minimum drum diameters.

All types of enforced guidance systems that could damage the belt edges, such as for example check strips, roller etc must be avoided.

If significant lateral forces occur, an automatic control device should be used.

The two halves of the table should only be fixed in position, or the guide strips attached, once the belt is running satisfactorily. Minimum play must be retained to allow for tolerances.

Increase the groove depth h if the system is exposed to significant soiling. If two longitudinal profiles are used, the dimension z must be big enough.

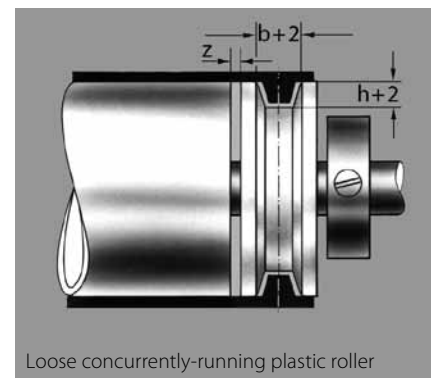
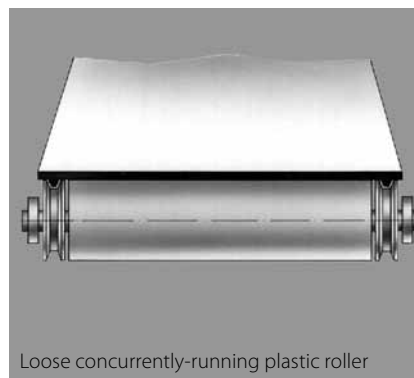
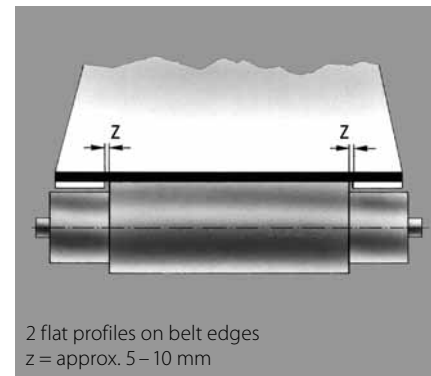
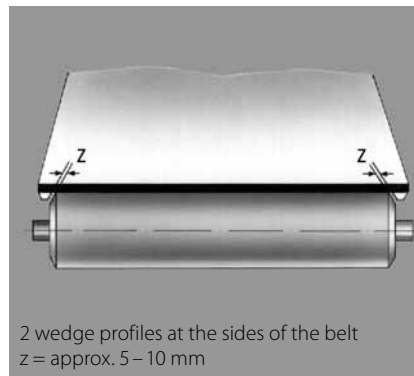
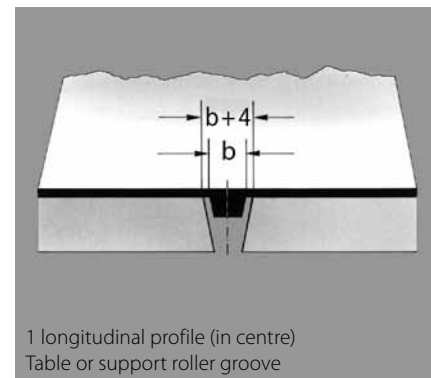
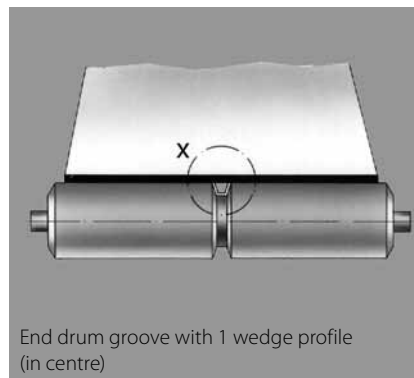
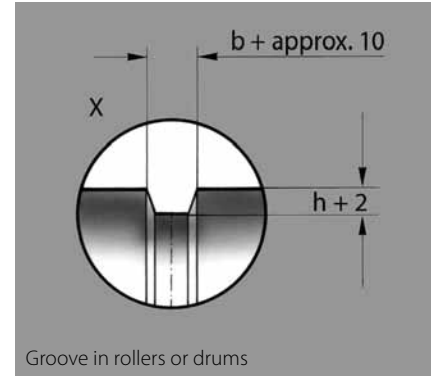
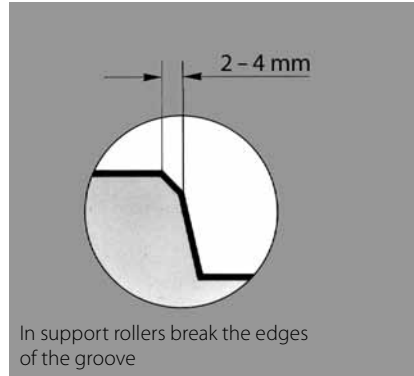

Bending of drums and rollers

Excessive drum deflection is often the cause of tracking problems in wide belts.

Reasons for deflection:

- Belt pull increasing proportionately to the width of the belt
- Drum diameters are small due to technical requirements.

Therefore, please ensure that the following values are not exceeded:

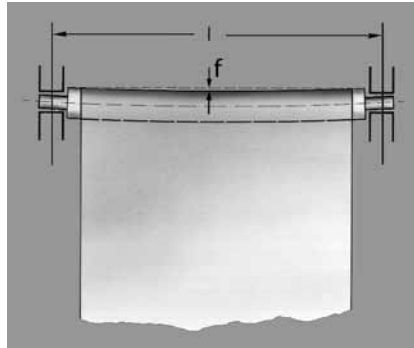

- Tapered/cylindrical drum deflection $y_{Tr} \leq 0.5 h$,
- in cylindrical drums greater deflection of $y_{Tr} \leq h$ is permitted
- See drive drums for h values.

- F_R = Active force [N] (line load) resulting from belt pull and drums' own weight.
- $F_R = \sqrt{(2 \cdot \varepsilon \cdot k_{1\%} \cdot b_0)^2 + (9.81 \cdot m_{Tr})^2}$
- l = Bearing centre distance [mm]
- d, d_a, d_i = Shaft diameter [mm]
- y_{Tr} = Drum deflection [mm]
- m_{Tr} = Drum weight [kg]
- $k_{1\%}$ = Relaxed belt pull [N/mm] at 1% elongation

Example

A 2500 mm wide Siegling Transilon belt, type E 12/2 U0/UH, rotates around a steel drum, 150 mm in diameter and 10 mm thick at an arc of contact of 180°. The belt runs horizontally.

E 12/2 approx. 0.2 to 0.3% tensioned
 Drum weight = 27 kg
 E = modulus of elasticity N/mm²
 E for steel = $2.1 \cdot 10^5$ N/mm²

l = 2600 mm
 d_a = 150 mm
 d_i = 130 mm
 $k_{1\%}$ = 12

$$F_R = \sqrt{(2 \cdot 0.3 \cdot 12 \cdot 2500)^2 + (9.81 \cdot 27)^2} = 18002 \text{ N}$$

$$y_{Tr} = \frac{80 \cdot 18002 \cdot 2600^3}{96 \cdot 2.1 \cdot 10^5 \cdot (150^4 - 130^4) \cdot \pi}$$

$$y_{Tr} 1.81 > 0.35 \text{ mm} = f_{zul}$$

Reinforced by central brace

$$y_{Tr} = \frac{80 \cdot 9001 \cdot 1300^3}{96 \cdot 2.1 \cdot 10^5 \cdot (150^4 - 130^4) \cdot \pi}$$

$$y_{Tr} = 0.23 \text{ mm} < 0.35 \text{ mm}$$

Solid drum

$$y_{Tr} = \frac{80 \cdot F_R \cdot l^3}{E \cdot d^4 \cdot \pi \cdot 96} \quad [\text{mm}]$$

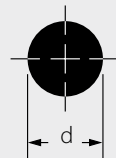

Tubular drum

$$y_{Tr} = \frac{80 \cdot F_R \cdot l^3}{E \cdot (d_a^4 - d_i^4) \cdot \pi \cdot 96} \quad [\text{mm}]$$

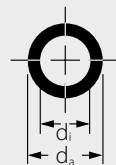

Seal strips

Where light bulk goods are concerned, seal strips made of the conveyor belt material can be a good low-friction solution that seals at the same time.

Contact Forbo Siegling application engineers to help you choose suitable belt types.

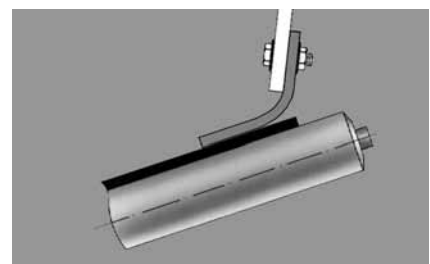

BELT TRACKING

Sideskirts

Hopper walls or guide strips should open in the direction of belt travel to prevent the products sticking between the sideskirt (strip) and belt. They should be as flush with the belt as necessary for the particular product in

question. Sideskirts resting on the belt increase the effective pull. Take this increase into account when sizing the belt. Apply sideskirts at right angles to the belt.

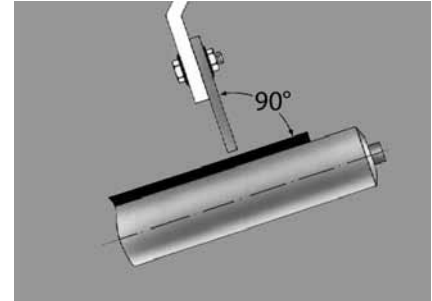

Product discharge

Unit goods are frequently discharged or transferred from the belt at the sides. In this case, ensure that the lateral forces acting on the belt are kept to a minimum. Swivel-mounted ploughs that do not touch the belt are commonly used.

To avoid the belt mistracking when it conveys the products upwards or downwards, we recommend as follows:

- Lag the support rollers in the feed zone with a friction lagging to increase the friction coefficient between the support rollers and the belt (see above).
- Make changes in the design to increase the areas of belt wrap in the feed zone (see below).

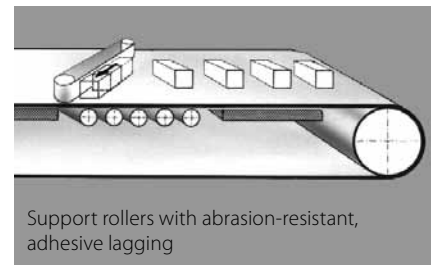

Greater force is required in the case of multiple belt wraps due to counter bending and where low temperatures occur. By inserting a tapered/cylindrical drum, belt tracking can be stabilised at the sides too.

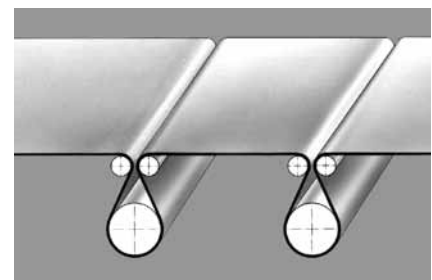

The belt cannot be guided via the belt edge in light conveyor belts.

Product feed

During loading operations, the conveyor belt is subjected to mechanical stress vertically (from impact) and tangentially due to the relative velocity between the goods conveyed and the belt.

The designer's task is to provide systems that enable the product to be fed onto the belt gently and at a similar (or ideally the same velocity) in the direction of belt travel. The products should be placed on the middle of the belt, to avoid the belt mistracking (for example using chutes, guide plates, funnels, feed hoppers etc.).

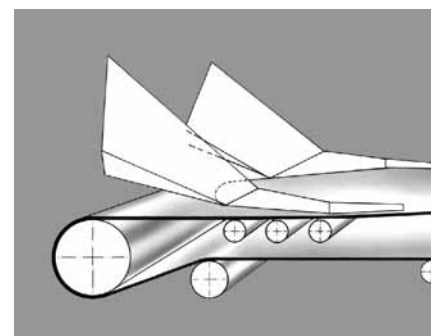

CLEANING DEVICES

Scrapers

There are a number of methods for removing product residues that have stuck to the conveyor belt. How effective these methods are does however depend on the conditions at hand. In many instances, one or more scrapers are sufficient: strips made of plastic or rubber in a smooth or profile steel frame, in a transverse position to the direction of belt travel. It is important to select the scraper material carefully (do not use any old pieces of conveyor belt, as this will cause unnecessary wear and tear on the conveyor belt).

The belt scraper (a) should be placed as closely as possible to the belt or touch it slightly. Since the scraper is subject to wear and tear, an adjustment method (slots etc) must be provided.

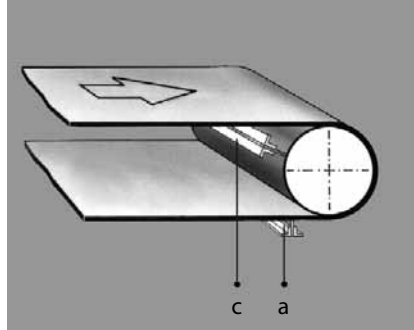

Smooth drums without any lagging can be kept clean with scrapers made of steel (c). These scrapers can be mounted flush with the surface of the drum and match the shape (e.g. trapezoidal) of the drum.

When cleaning devices are used, allowances must be made when calculating the power consumption:

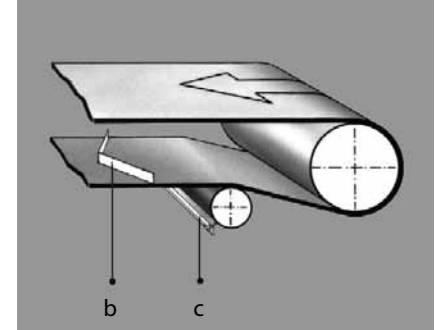

When cleaning devices are used, allowances must be made when calculating the power consumption:

$$F_A = \text{Contact force}$$

$$F_{UR} = \text{Effective pull of the cleaning device}$$

$$P_R = \text{Power consumption of the cleaning device}$$

$$F_{UR} = F_A \cdot \mu$$

$$P_R = \frac{F_{UR} \cdot V}{1000}$$

Brushes

To clean the belt, rotating brushes or belt cleaning systems can be used. If the products conveyed are very sticky, a water spray system or a water immersion system ensure the brushes do not clog up.

Please note:
If cleaning devices are improperly fitted, forces can occur at the sides that cause the belt to mistrack.

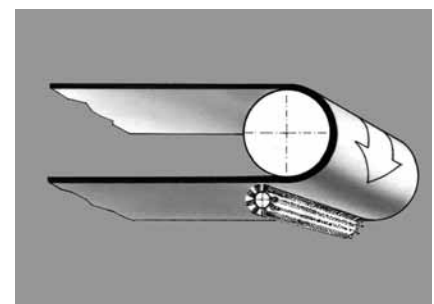

Siegling – total belting solutions

Committed staff, quality oriented organization and production processes ensure the constantly high standards of our products and services.

Forbo Movement Systems complies with total quality management principles. Our quality management system has ISO 9001 certification at all production and fabrication sites. What's more, many sites have ISO 14001 environmental management certification.



Ref. no. 305-2
02/21 - UDH - Reproduction of text or parts thereof only with our approval. Subject to change.



Forbo Siegling service – anytime, anywhere

The Forbo Siegling Group employs around 2,400 people. Our products are manufactured in ten production facilities across the world. You can find companies and agencies with warehouses and workshops in over 80 countries. Forbo Siegling service points are located in more than 300 places worldwide.

Forbo Siegling GmbH

Lilienthalstrasse 6/8, D-30179 Hannover
Phone +49 511 6704 0
www.forbo-siegling.com, siegling@forbo.com



MOVEMENT SYSTEMS